

Frigidaire

INTERNATIONAL

Factory Parts Catalog

| | |
|---------------------------|-------------|
| Product No. | FGTD20V4CWC |
| Series | 134A SYSTEM |
| Color | white |
| Volts | 220 |
| Wiring Diagram | 240583901 |
| Owner's Guide | 240432700 |
| Market | Export |
| Energy Guide | 240460365 |
| Service Data Sheet | 240586202 |
| Installation Instructions | 240568301 |

INTERNATIONAL
3 Parkway Center, Pittsburgh, PA 15220

Publication No.
5995480661
06/12/12
(EN/SERVICE/KHB)
390

TOP-MOUNT REFRIGERATOR

Model No.
FGTD20V4C

Copyright © 2006 Electrolux Home Products, Inc.
All rights reserved.

DOOR

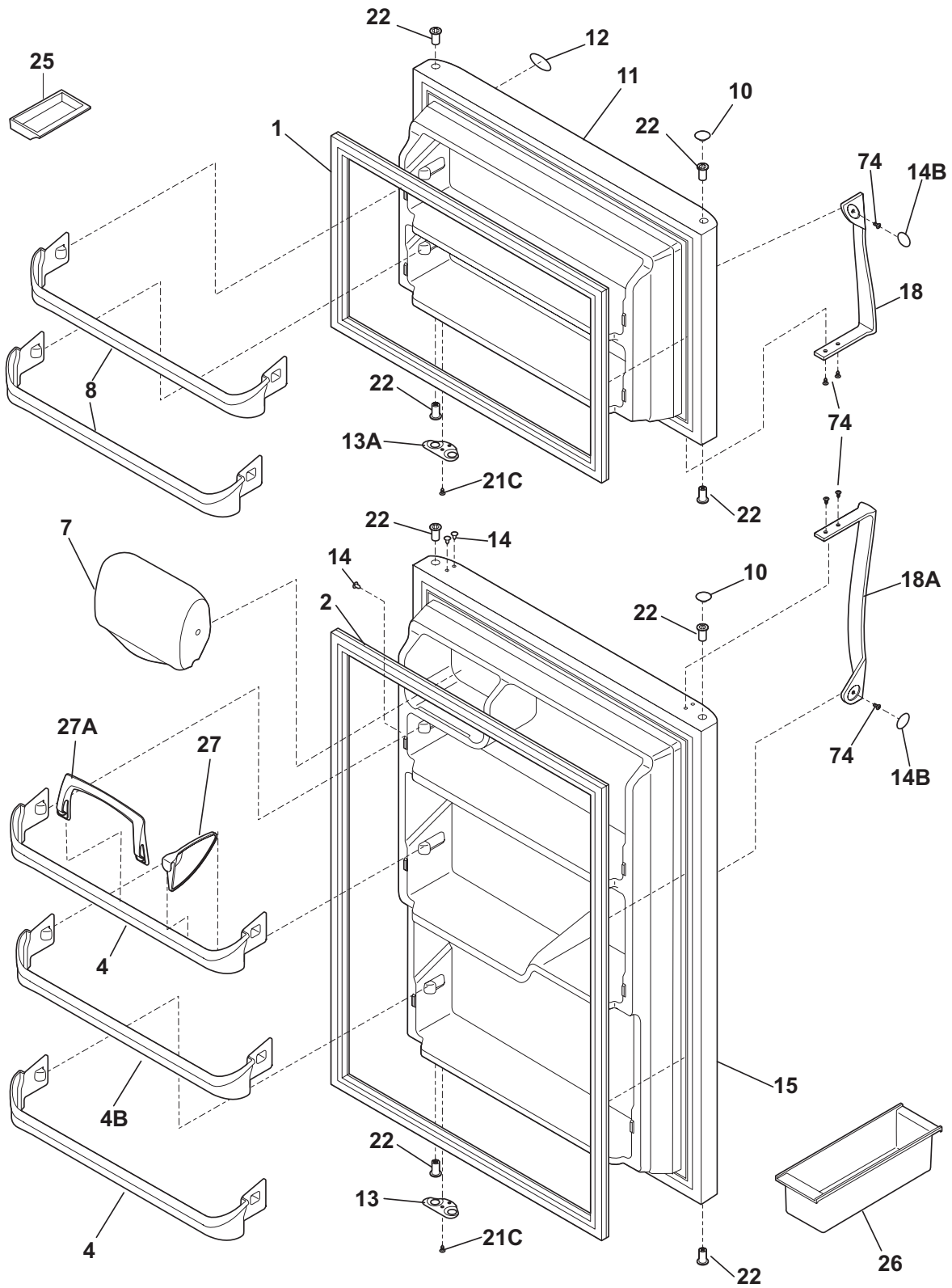

N05DCDCKA2

DOOR

| POS. NO | PART NO. | DESCRIPTION |
|---------|------------|---|
| 1 | 240542115 | Gasket-frzr door, white, magnetic |
| 2 | 240542118 | Gasket-refr door, white, magnetic |
| 4 | 240534901 | Rack-door |
| 4B | 240534701 | Rack-door, 4B |
| 7 | 240337712 | Door-dairy |
| 8 | 240534801 | Rack-door |
| 10 | 240381301 | Plug-button, white, hinge brg hole, (2) |
| 11 | 240409901 | Door-frzr, white, complete assy |
| 12 | 240589601 | Label-nameplate |
| 13 | 240312403 | Door Stop, white, ref |
| 13A | 240312404 | Door Stop, white, frzr |
| 14 | 240494001 | Plug-button, white |
| 14B | 240383601 | Plug-button, white, door handle |
| 15 | 240410001 | Door-refr, white, complete assy |
| 18 | 240339201 | Handle-door, white, refr-LH/frzr-RH |
| 18A | 240339206 | Handle-door, white, refr-RH/frzr-LH |
| 21C | 218252201 | Screw, #8 truss hd, 10-32CA x 0.500 |
| 22 | 240527101 | Bearing-hinge, natural color |
| 25 | 5308000716 | Dish, butter |
| 26 | 3204522 | Container, egg |
| 27 | 240396302 | Snugger, paddle type |
| 27A | 240396102 | Retainer, tall bottle |
| 74 | 240383406 | Screw, truss hd quad, #10-16 x .500, zinc |

CABINET

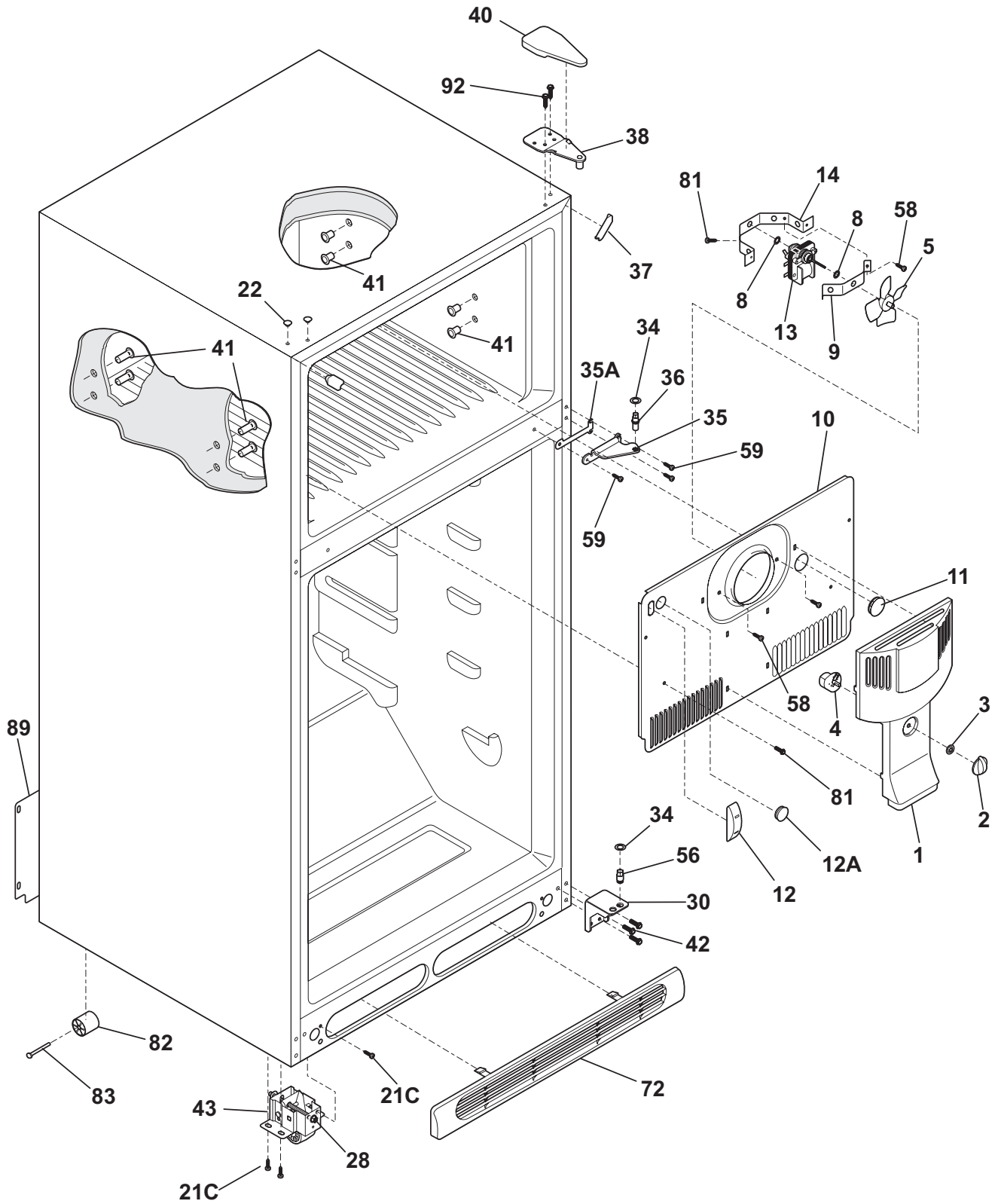

N05BBAABA17

CABINET

| POS. NO | PART NO. | DESCRIPTION |
|---------|------------|--|
| 1 | 241652301 | Cover-fan |
| 2 | 240367001 | Knob-damper control |
| 3 | 5303001028 | Nut, push-on |
| 4 | 240367401 | Damper-fan cover |
| 5 # | 5308000010 | Fan Blade, red, evaporator fan |
| 8 | 5300157666 | Bushing-motor mtg, (2) |
| 9 | 5303292396 | Bracket-motor mtg, front |
| 10 | 241652214 | Cover-evap coil |
| 10* | 240568601 | Seal-coil cover |
| 10*# | 241520701 | Harness-wiring, freezer |
| 11 | 5303208309 | Plug-hole, factory test |
| 12 | 241557601 | Plug-ice maker harness, rectangular |
| 12A | 240374401 | Plug-wtr inlet tube, round, 1" |
| 12A* | 241586701 | Plug-foam-wtr-inlet, round |
| 13 # | 240419703 | Motor-evap fan |
| 13* | 215474201 | Washer, "slinger", nylon, evap fan shaft |
| 13* | 218931001 | Clamp-motor wiring, nylon, w/adhesive tape |
| 14 | 5303292397 | Bracket-motor mtg, rear |
| 21C | 218252201 | Screw, #8 truss hd, 10-32CA x 0.500 |
| 22 | 215774901 | Plug-button, white, upr hinge holes |
| 28 | 241708801 | Bolt-roller adj, hex washer head, 1/4-20 x 4.020, (2), special |
| 30 | 240314011 | Bracket-lower hinge, zinc |
| 34 | 240311303 | Washer, hinge, nylon, (2) |
| 35 | 240313806 | Bracket-ctr hinge, zinc |
| 35A | 240336802 | Spacer-hinge, center |
| 36 | 240516402 | Pin-center hinge |
| 37 | 241611301 | Trim-cabinet corner, white, (2) |
| 38 | 240313701 | Bracket-upper hinge |
| 40 | 240354401 | Cover-upper hinge, white |
| 41 | 5308009759 | Grommet, shelf mtg, 1.25", LH, (4) |
| 42 | 240578902 | Screw-hinge mtg, hex head, 1/4-20 x 5/8 |
| 43 | 241709301 | Roller Assy, adjustable, front, (2) |
| 56 | 240516502 | Pin-lower hinge |
| 58 | 5304456287 | Screw, hex washer head, 8-15A x 0.500 |
| 59 | 240442706 | Screw-#10-32 X 3/4, zinc |
| 72 | 240368205 | Grille/Kickplate, white |
| 81 | 240433204 | Screw, hex washer head, 8-18 x 5/16 |
| 82 | 5304418225 | Roller, compressor base, rear, (2) |
| 83 | 5304455655 | Rivet, flat head, 1/4 OD x 1-3/4, roller pin |
| 89 | 240326119 | Cover-access, with label |
| 89* | 241500304 | Screw, hex washer head, 8-18AB x 0.625 |
| 92 | 241710601 | Screw, hex washer hd, 1/4 x 7/8, hinge mtg |
| * | 218515401 | Clip |
| * | 5303321319 | Paint, touch-up, white |

SHELVES

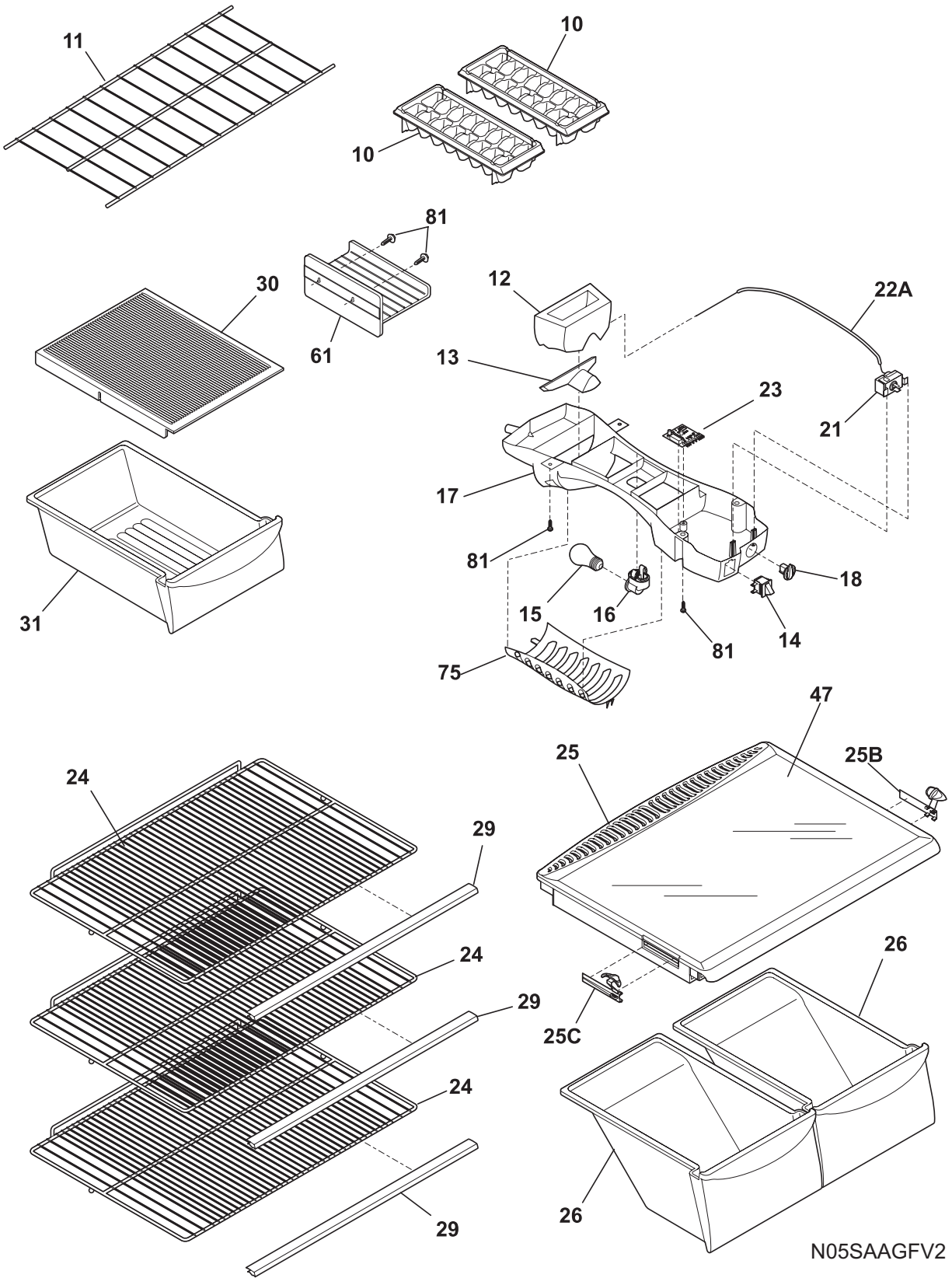

N05SAAGFV2

SHELVES

| POS. NO | PART NO. | DESCRIPTION |
|---------|------------|--|
| 10 | 215667501 | Tray, ice cube, plastic |
| 11 | 240358005 | Shelf, freezer, full-width, wire |
| 12 | 240545001 | Diffuser, air, top |
| 13 | 240362601 | Diffuser, air, bottom |
| 14 | 241554901 | Switch-light/lamp |
| 15 | 218814401 | Light Bulb |
| 16 # | 240433702 | Socket-light/lamp |
| 17 | 240352701 | Control Box |
| 17*# | 240375502 | Wiring Harness, control box |
| 18 | 240360801 | Knob, temp control |
| 21 # | 5304458064 | Control-temperature |
| 22A | 240468201 | Tube, sensor sleeve, 31 inch, plastic, white |
| 23 # | 240545402 | Control-defrost, adaptive timer, 220/240 V, PC board |
| 23* | 5304455649 | Screw-timer mtg, pan hd, 6-20 x 0.438, (2) |
| 24 | 240360905 | Shelf, sliding, wire |
| 25 | 240364714 | Cover-crisper pan |
| 25B | 241613501 | Control-humidity, RH |
| 25C | 241613502 | Control-humidity, LH |
| 26 | 240337103 | Pan-crisper, clear, (2), no graphics |
| 29 | 240430708 | Trim-shelf |
| 30 | 240361801 | Cover, meat pan hanger, drop through |
| 31 | 240530811 | Pan-meat, w/o graphics, clear |
| 47 | 241711219 | Insert-pan cover, glass |
| 61 | 215781501 | Shelf, ice tray mount, wire |
| 75 | 240412701 | Shield, light |
| 81 | 5304455650 | Screw, hex washer head, 8-15A x 0.625, low profile |

SYSTEM

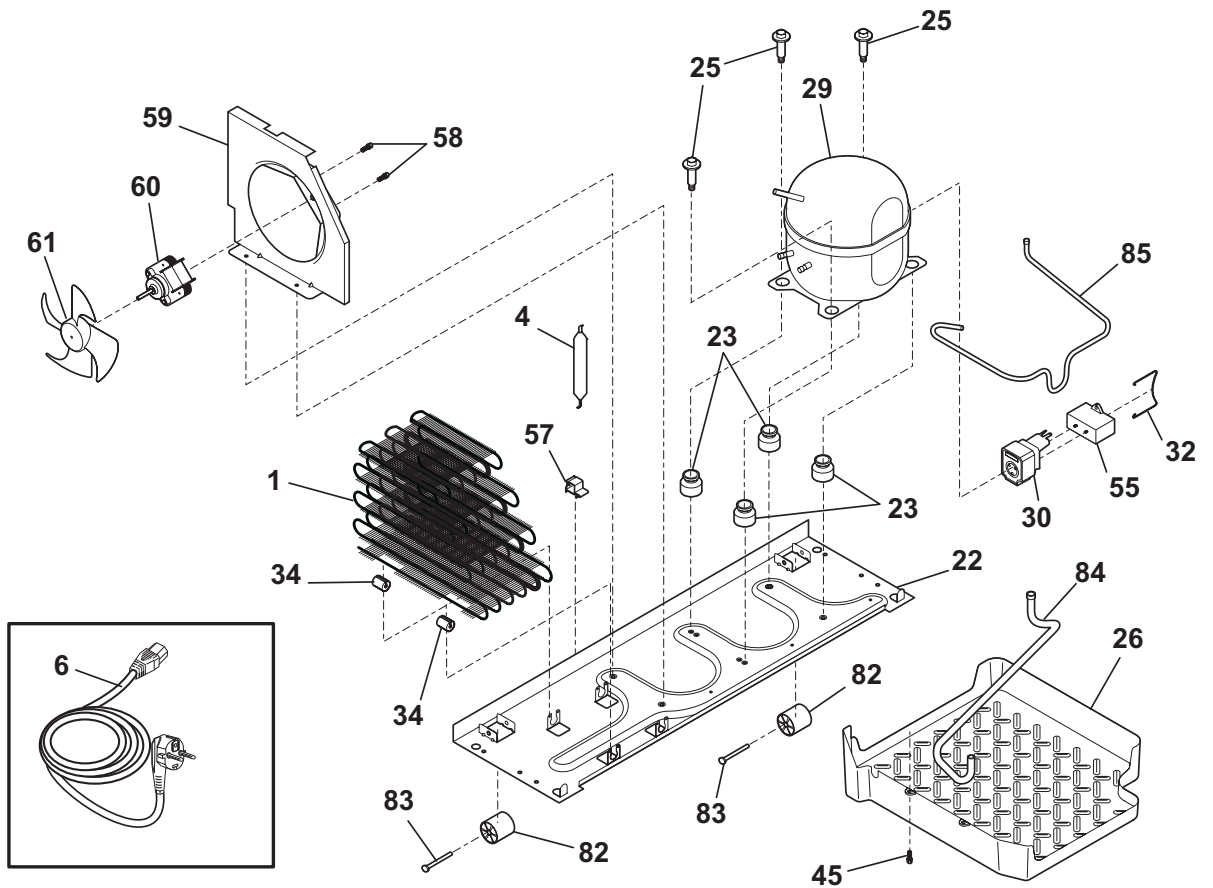
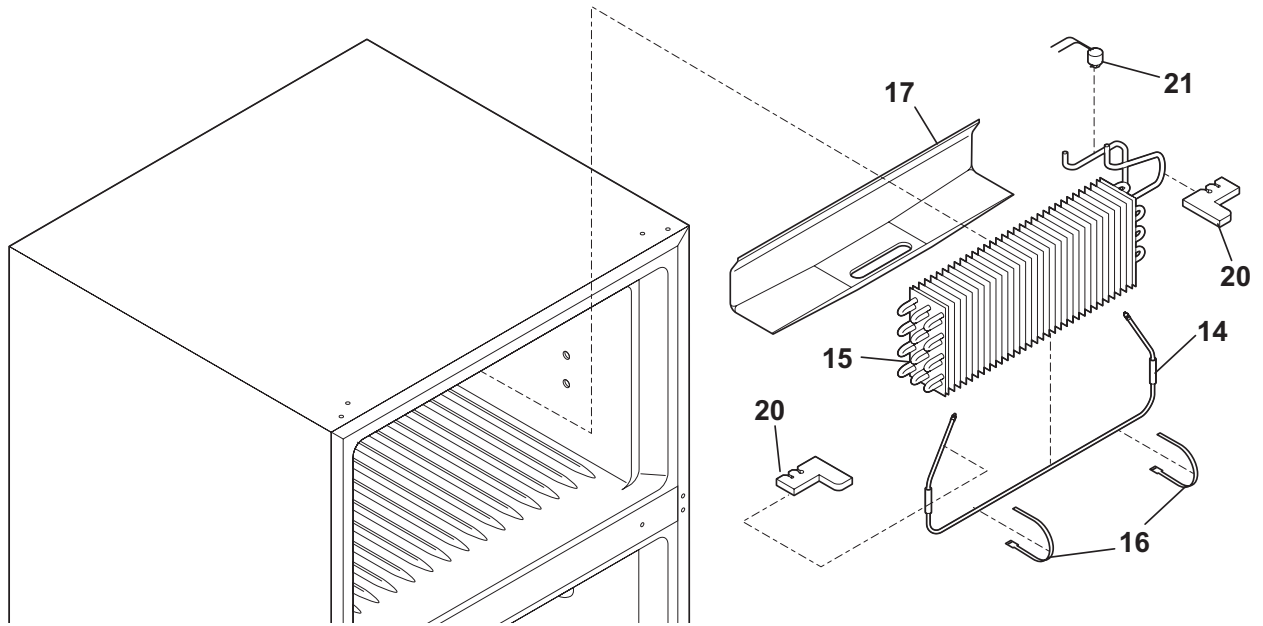

N05CAAAAA26

SYSTEM

| POS. NO | PART NO. | DESCRIPTION |
|---------|------------|---|
| 1 # | 241665702 | Condenser, dynamic |
| 4 # | 218944001 | Drier-filter, R134a System |
| 6 | 240449501 | Cord-electric power |
| 6* | 240447102 | Bracket, strain relief |
| 6* | 240447201 | Clamp, strain relief |
| 6* | 240451503 | Screw, ind hex wshr hd, 8-32 x 0.375, trilobe |
| 6* | 241626401 | Harness-wiring, machine compt |
| 6* # | 240375502 | Wiring Harness, control box |
| 6* # | 241520701 | Harness-wiring, freezer |
| 14 # | 240356216 | Defrost Heater, 220 V |
| 15 # | 5303918274 | Evaporator Kit |
| 16 | 5308000110 | Strap-evap/heater, aluminum, (2) |
| 17 | 241551801 | Trough-drain |
| 20 | 241551901 | Insulation Block |
| 21 # | 5303918202 | Thermostat-defrost, kit |
| 22 | 241665503 | Base-compressor |
| 22* | 218252201 | Screw, #8 truss hd, 10-32CA x 0.500 |
| 23 | 218513300 | Grommet-compr mtg, (4) |
| 25 | 240491503 | Screw-compressor mtg, 1/4-28 x 1.16, (4) |
| 26 | 241683601 | Pan-defrost |
| 29 | 5303918343 | Compressor, w/electricals |
| 30 | 241524610 | Starter-PTC |
| 32 | 240553401 | Clamp, elec cont mtg, compressor |
| 34 | 240405201 | Grommet, rubber, black, cond tube/wire |
| 45 | 241500304 | Screw, hex washer head, 8-18AB x 0.625 |
| 55 # | 218909908 | Capacitor, run |
| 57 | 240542601 | Clip-wiring harness |
| 58 | 218897004 | Screw, hex washer head, 8-32 x 0.375 |
| 59 | 5304430246 | Bracket-cond motor assy |
| 59* | 240346701 | Tape-foam seal, shroud |
| 59* | 240359403 | Screw-fan shroud, (2) |
| 60 # | 240525405 | Motor-condenser fan |
| 61 # | 240524101 | Fan Blade, galv steel, condenser fan |
| 82 | 5304418225 | Roller, compressor base, rear, (2) |
| 83 | 5304455655 | Rivet, flat head, 1/4 OD x 1-3/4, roller pin |
| 84 | 240359601 | Tube-drain, lower |
| 85 | 240553501 | Tube-connector, suction |
| * | 5303918263 | Heat Exchanger Kit, suction line |
| * # | 5303918241 | Hot Tube Repair Kit, 220 V, service |

WIRING SCHEMATIC

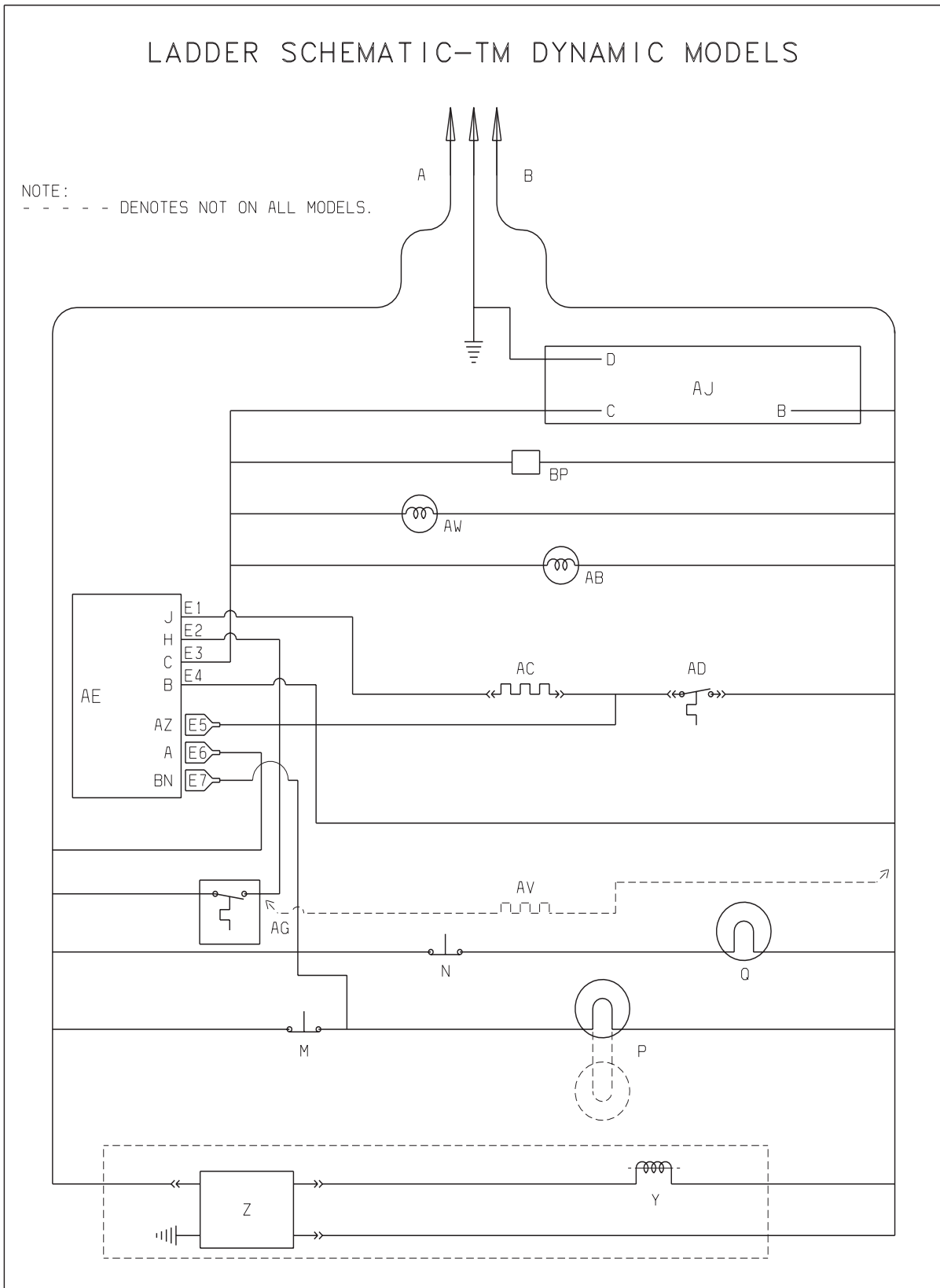

WIRING DIAGRAM

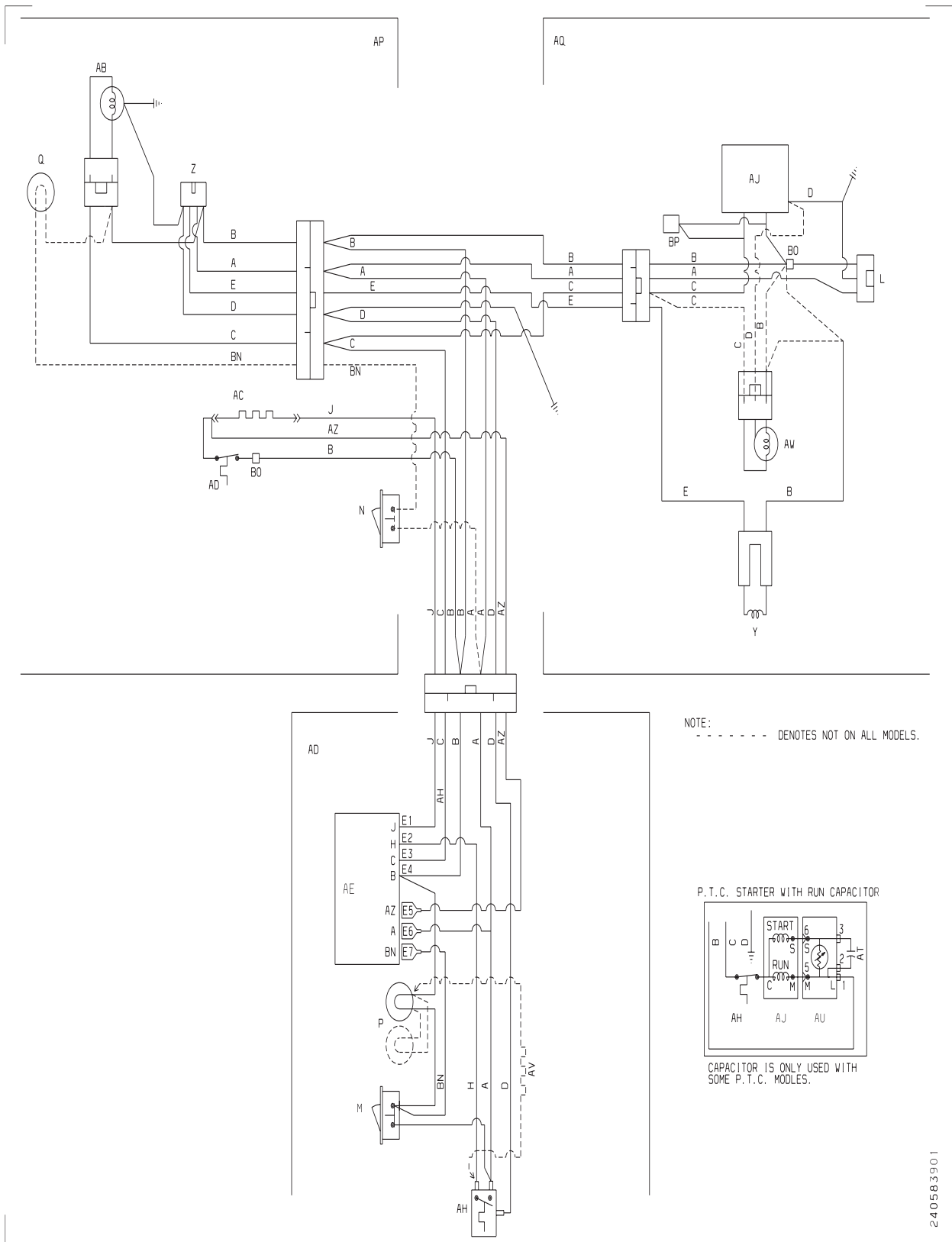

NOTE: - - - - DENOTES NOT ON ALL MODELS.

P.T.C. STARTER WITH RUN CAPACITOR

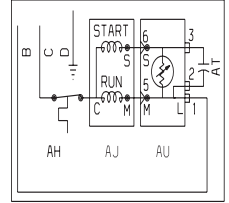

CAPACITOR IS ONLY USED WITH SOME P.T.C. MODELS.

240563901